



COMBUSTION TECHNOLOGIES

Combustion Engine By-Pass Filtration Specifications

- Part # CT-CBFK-1
- Material: Aluminum Head Unit
- Application: Combustion Engine Oil
- Filter Thread Size: 1.5" x 16 UNF
- Shipping Weight: 10.5 Lbs.
- Flow Rate: 1.2 GPM at 40psi
- Element: Synthetic Media
- Filtration Rating: 3-Micron
- Filter Efficiency: ISO 16889, Beta 1000
- Max Pressure: 160 psi
- Max Temperature: 260 (degrees F)
- Viscosity Range: 10-220 cSt @ 100
- Sump Capacity: Up to 15 Gallons
- Filtration Retention: 400 ml combined (13.5oz)
- Inlet / Outlet Fitting Size: 4 MJIC



Combustion Technologies CT-510SPC Filter Dimensions

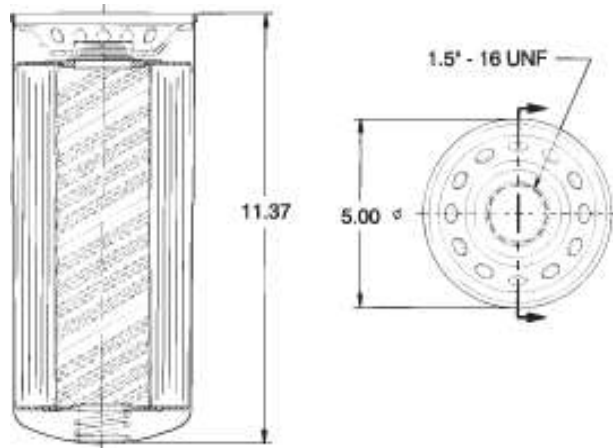

Combustion Technologies USA

www.combustionusa.com