



- Swing bolt closure for quick and secure filter change
- Heavy duty 304 stainless steel
- Legs are standard

HYDRONIX BF SERIES BAG FILTER HOUSINGS

Are ideal for most industrial/commercial applications. Our welded leg design as a standard feature, eliminates the added expense to your application. Commonly used for pre-filtration to reverse osmosis (RO) systems, farms, food service, car washes, agriculture and many other uses.

HYDRONIX BF SERIES BAG FILTER HOUSINGS

Use a high grade 304 stainless steel as standard (not "L"), which is a lower grade stainless steel used by other brands.



BF SERIES

Stainless Steel Bag Filter Housings

Materials of Construction

| | |
|---------------------|--|
| Housing: | 304 stainless steel |
| Closure: | Stainless Steel |
| O-Ring: | EPDM (FDA Grade) |
| Max. Pressure/Temp: | 150 PSI at 200°F (10.34 bar at 93.33°C) |

Standard Features

- Electro polishing
- Legs

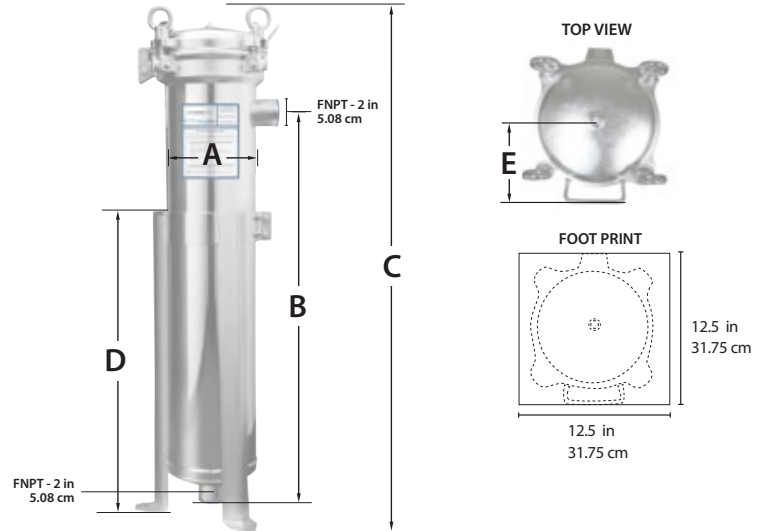

Filter Housing Dimensions

| Part # | A | B | C | D | E |
|------------|-------------------|------------------|-----------------|--------------------|-------------------|
| | Width | To Outlet | Inlet to Top | Leg Height | Gauge Port |
| BF1-304-2N | 8.5 in 21.6 cm | 21 in 53.3 cm | 8 in 20.3 cm | 19.5 in 49.5 cm | 6.5 in 16.5 cm |
| BF2-304-2N | 8.5 in 21.6 cm | 36 in 91.4 cm | 8 in 20.3 cm | 27.5 in 69.8 cm | 6.5 in 16.5 cm |

BF SERIES FLOW RATES

| Part # | Description | Flow Rate | |
|------------|---|-----------|-------|
| | | GPM | LPM |
| BF1-304-2N | 304SS Bag Filter Housing , 150 PSI, 2" FNPT | 90 | 340.6 |
| BF2-304-2N | 304SS Bag Filter Housing , 150 PSI, 2" FNPT | 180 | 681.3 |

Distributed by:

HYDRONIX WATER TECHNOLOGY

P.O. Box 927, Chino Hills, CA 91709 USA
 sales@hydronixwater.com • www.HydronixWater.com